

AUTOMATIC MIXING VALVE : Model TM AUTOMATIC SELECTOR VALVE : Model TS

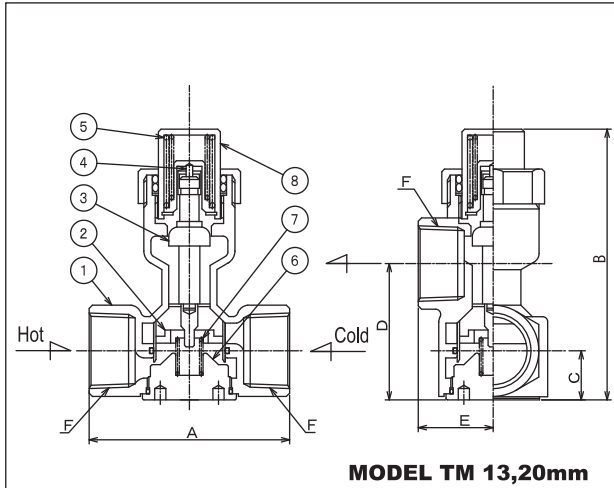

●Dimensions: unit : mm

Nom. Size	A	B	C	D	E	F
13	60	86	15	38.5	24	Rc1/2
20	70	96.5	17	47.5	26	Rc3/4

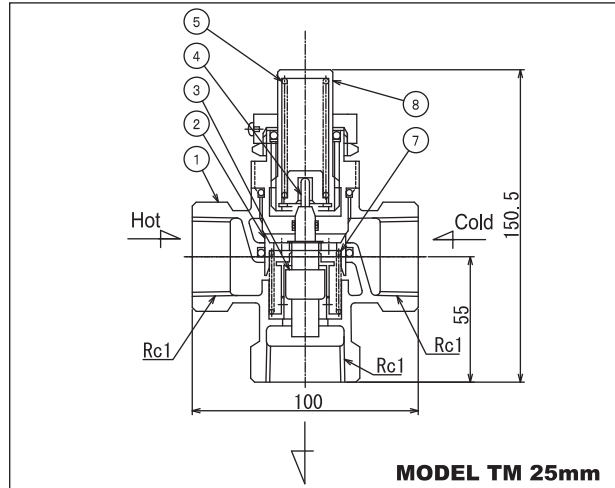

●Materials:

No.	Description	Material
1	Body	CAC406
2	Disk	C3604BD
3	Thermo pellet	—
4	Piston	SUS304
5	Spring	SUS304WPB
6	Valve seat	C3604BD
7	Spring	SUS304WPB
8	Control handle	C3604BD

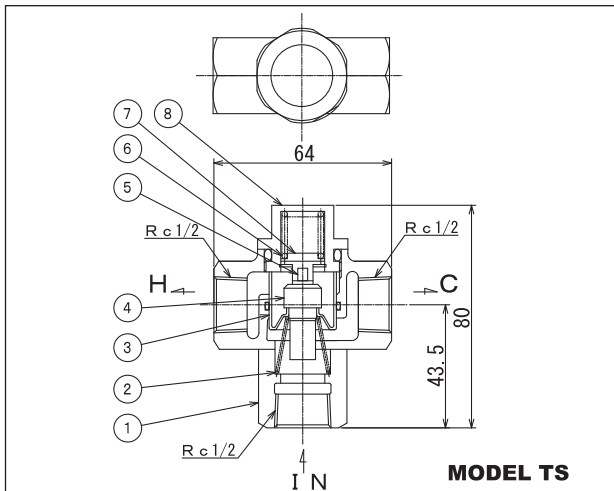

●Materials:

No.	Description	material
1	Body	CAC406
2	Spring	SUS304WPB
3	disk	SUS430
4	Thermo pellet	—
5	Piston	SUS304
6	Spring	SUS304WPB
7	Spring cover	C3604BD
8	Cap	C3604BD

●Diagram:

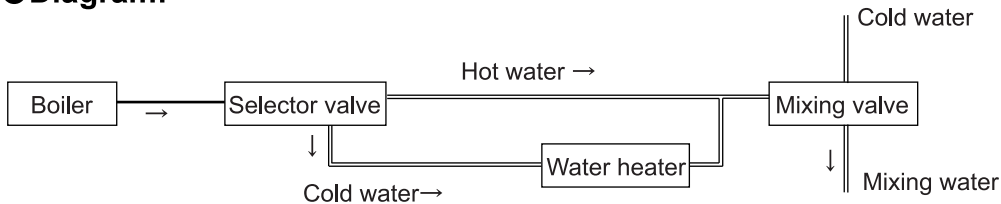

ISO9001 Certified

Japanese Industrial Standard Permitted Factory
Japan Water Works Association Authorized Factory

KKK KANE KOGYO Co., Ltd.

Head office and factory : 2036 Okusa, Komaki-shi, Aichi-ken 485-0802 Japan

TEL : 81-568-79-2476 FAX : 81-568-79-6422

Web site: <http://www.kkk-kane.co.jp> E-mail: overseasales@kkk-kane.co.jp